

This article was downloaded by:

On: 25 January 2011

Access details: *Access Details: Free Access*

Publisher *Taylor & Francis*

Informa Ltd Registered in England and Wales Registered Number: 1072954 Registered office: Mortimer House, 37-41 Mortimer Street, London W1T 3JH, UK



Liquid Crystals

Publication details, including instructions for authors and subscription information:

<http://www.informaworld.com/smpp/title~content=t713926090>

Non-linear dielectric response of a ferroelectric liquid crystal

S. K. Prasad; G. G. Nair; D. S. Shankar Rao

Online publication date: 06 August 2010

To cite this Article Prasad, S. K. , Nair, G. G. and Rao, D. S. Shankar(1999) 'Non-linear dielectric response of a ferroelectric liquid crystal', *Liquid Crystals*, 26: 11, 1587 – 1590

To link to this Article: DOI: 10.1080/026782999203562

URL: <http://dx.doi.org/10.1080/026782999203562>

PLEASE SCROLL DOWN FOR ARTICLE

Full terms and conditions of use: <http://www.informaworld.com/terms-and-conditions-of-access.pdf>

This article may be used for research, teaching and private study purposes. Any substantial or systematic reproduction, re-distribution, re-selling, loan or sub-licensing, systematic supply or distribution in any form to anyone is expressly forbidden.

The publisher does not give any warranty express or implied or make any representation that the contents will be complete or accurate or up to date. The accuracy of any instructions, formulae and drug doses should be independently verified with primary sources. The publisher shall not be liable for any loss, actions, claims, proceedings, demand or costs or damages whatsoever or howsoever caused arising directly or indirectly in connection with or arising out of the use of this material.

Non-linear dielectric response of a ferroelectric liquid crystal

S. K. PRASAD*, G. G. NAIR and D. S. SHANKAR RAO

Centre for Liquid Crystal Research, Jalahalli, Bangalore 560 013, India

(Received 26 March 1999; accepted 27 May 1999)

Dielectric spectroscopy is a very useful method for investigation of the structure and dynamics of liquid crystals. However, with few exceptions, most investigations have been only in the linear regime. In this note we present a simple method for extraction of the non-linear contributions to the dielectric constant and as an example give the results obtained for a ferroelectric liquid crystal.

1. Introduction

The dielectric behaviour of ferroelectric liquid crystals has been studied quite exhaustively [1]. However, with few exceptions, all these investigations are restricted to the linear part of the sample response to the applied electric field. The non-linear response has not been well investigated. The reasons for this are two-fold: (a) the signal due to the non-linear part is very small compared with that due to the linear part and therefore difficult to extract; (b) there is no commercially available equipment with which to perform these measurements. Early work in this field appears to have been started by Rzoska *et al.* [2]. Their experiment, based on a principle developed by Chelkowski [3] for general dielectric materials, employs the application of large pulsed voltages to the sample and measurement of the dielectric constant with a small probing field. The difference between the values obtained with and without the large pulsed voltage gives a measure of the non-linearity of the response. By applying voltages in the range 200–1000 V, they were able to study the temperature variation of the non-linear dielectric constant in the isotropic phase on approaching the nematic phase. But the disadvantage of the technique is the need for application of high voltages.

A second technique reported in the literature is based on Nakada's phenomenological theory [4] of multi-time after-effect functions and involves applying a low amplitude sinusoidal field to the sample and measuring the electrical displacement at past multi-time point. Translated to the frequency regime this is equivalent to measuring the displacement response at the fundamental and harmonic frequencies of the applied field. If the

amplitude of the field is E_0 and the angular frequency is ω , then the different components of the displacement can be written as

$$\begin{aligned} D_1 &= \epsilon_1 E_0 + \frac{3}{4} \epsilon_3 E_0^3 + \dots \\ D_2 &= \frac{1}{2} \epsilon_2 E_0^2 + \frac{1}{2} \epsilon_4 E_0^4 + \dots \\ D_3 &= \frac{1}{4} \epsilon_3 E_0^3 + \frac{5}{16} \epsilon_5 E_0^5 + \dots \end{aligned} \quad (1)$$

and so forth. Since the applied electric field is weak, the practice [5–7] is to neglect the higher order terms on the right hand side of each expression in equation (1) and retain only the first terms. As we shall see later, this assumption is supported by the raw values obtained for the first and third harmonic signals. Hence D_1 is considered to be the linear response, and D_2 and D_3 to be the second and third harmonic responses, respectively. Correspondingly, ϵ_1 is the linear dielectric constant and ϵ_2 and ϵ_3 are the non-linear dielectric constants.

Using this principle, Furukawa *et al.* [5] designed an experimental set up to study solid state ferroelectric samples, which we briefly recall here. The field to be applied to the sample was digitally synthesized and the response of the sample was collected using a charge amplifier. The output of the charge amplifier was passed through a Sample & Hold module and an analogue-to-digital converter and transferred to a PC, where the multiple frequency responses were obtained by performing a Fourier transform of the data. Although cumbersome to implement, the technique provides high precision data. Kimura and Hayakawa [6] adapted this method to the study of ferroelectric liquid crystals. They used a storage oscilloscope to perform the functions

* Author for correspondence;
 e-mail: uclcr@giasbg01.vsnl.net.in

of the Sample & Hold module and the analogue-to-digital converter. In this communication we describe a much simpler method and present results obtained for a ferroelectric liquid crystal.

2. Experimental

A schematic diagram of our set-up is shown in figure 1. Here the charge-to-voltage conversion is done by a very low loss, good high frequency performance capacitor that was calibrated using a standard frequency response analyser (Solatron 1260). The remaining functions, namely, waveform generation, Sample & Hold, analogue-to-digital conversion and fast Fourier transform to provide the multi-harmonic responses, are all accomplished by a digital lock-in amplifier (EG&G PAAR model 7251). The lock-in technique also helps in drastically improving

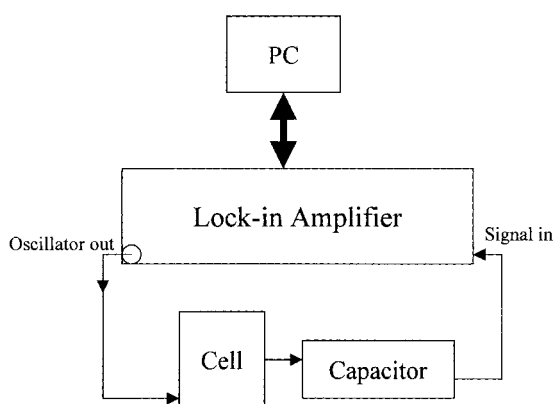

Figure 1. Schematic diagram of the experimental set-up used. The oscillator output of the lock-in amplifier is applied to the cell as a probing field; the sample response is collected as a voltage drop across a calibrated capacitor and is measured using the signal channel of the lock-in amplifier.

the signal-to-noise ratio; this is seen from the fact that data up to the seventh harmonic could be obtained. To demonstrate the use of this method, we have measured the multi-harmonic dielectric response of a commercially available ferroelectric liquid crystal, SCE12 (from E. Merck Ltd, UK), near its smectic A–smectic C* (A–C*) transition. The sample was sandwiched between ITO-coated glass plates, separated by Mylar spacers of 30 μm thickness. The glass plates were treated with a polyimide solution and unidirectionally rubbed for planar alignment. The amplitude of the applied voltage was 500 mV, which was much smaller than the helix-unwinding or equivalently polarization-reversal field in the C* phase. The frequency (11 Hz) of the applied field was much below the relaxation frequency of the Goldstone mode.

3. Results and discussion

The electric displacement (D_m) values obtained at the A–C* transition temperature for the fundamental ($m = 1$) and higher harmonics ($m = 3, 5$ and 7) are shown in figure 2. Because the value of D_m changes over three orders of magnitude, when m varies from 1 to 7, the data are presented on a logarithmic scale. The straight line fit of the $[\log(D_m), m]$ data shows that the non-linear response decreases exponentially with the harmonic number. Notice that the data for only the odd harmonics are shown. In fact, we found that the values for all the even harmonics, including for $m = 2$, to be negligibly small. The reason for this behaviour is as follows. The thickness of the cell used is much larger than the value of the helical pitch. In the C* phase, each individual smectic layer has the point group symmetry C_2 with the direction of the polarization pointing along the two-fold axis. However, chirality of the molecules induces a precession of the molecular tilt direction about the layer

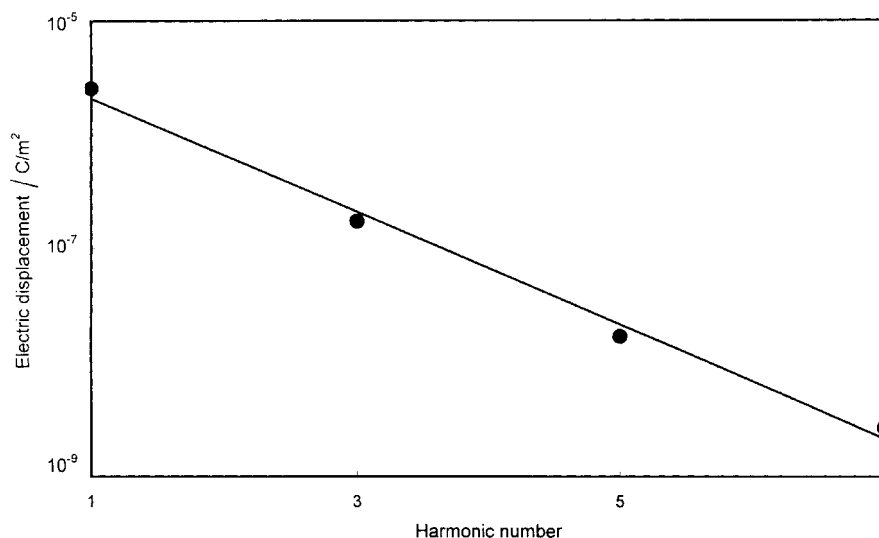

Figure 2. Plot of the electric displacement D_m measured at the A–C* transition as a function of the harmonic number m . The line shows a linear fit to the data and indicates that the variation is exponential.

normal, resulting in a helix. Owing to the coupling to the tilt direction, the direction of the polarization also precesses around the layer normal. Thus, if the sample thickness is much larger than the helical pitch, the global symmetry of the C* phase will be the same as that of the A phase, viz. D_{∞} and the system has a centre of symmetry. Therefore the even harmonics which can be present only in non-centrosymmetric systems are absent here. Similar results were obtained for solid state ferroelectric materials when the sample was unpoled [5].

As the amplitude of the applied field is small, D_m is almost proportional to E_0^m and the contributions from the higher order terms ($n > m$) in each of the expressions of equation (1) can be neglected. Hence we can write the linear and non-linear dielectric constants as $\epsilon_1 = D_1/E_0$, $\epsilon_3 = 4D_3/E_0^3$ and so on. The detailed temperature dependence of the linear and the non-linear constants thus calculated are shown in figure 3. To our knowledge, these are the first measurements of non-linear dielectric

constants for harmonic numbers > 3 . ϵ_1 shows a large increase across the transition and a slower increase inside the C* phase. This is indicative of the presence of the Goldstone mode, whose presence is expected for the thick cells used in this study. In contrast, the higher harmonics show a sharp peak at the transition. The trend observed for ϵ_3 is quite similar to those observed in other liquid crystalline materials [6, 7]. The sharp rise in the A phase followed by a steep drop in the C* phase has been attributed to the helical pitch variation with temperature; the data from our pitch measurements [8] in the C* phase corroborate this argument. The value of ϵ_3 observed close to the transition ($\sim 1.5 \times 10^{-19}$) is high compared with the one reported [7] for DOBAMBC, but is close to that for DOBA-1-MPC. It may be noted here that the spontaneous polarization values for DOBA-1-MPC and SCE12, the material studied here, are comparable ($\sim 17 \text{ nC cm}^{-2}$), whereas for DOBAMBC it is about three times smaller [9, 10].

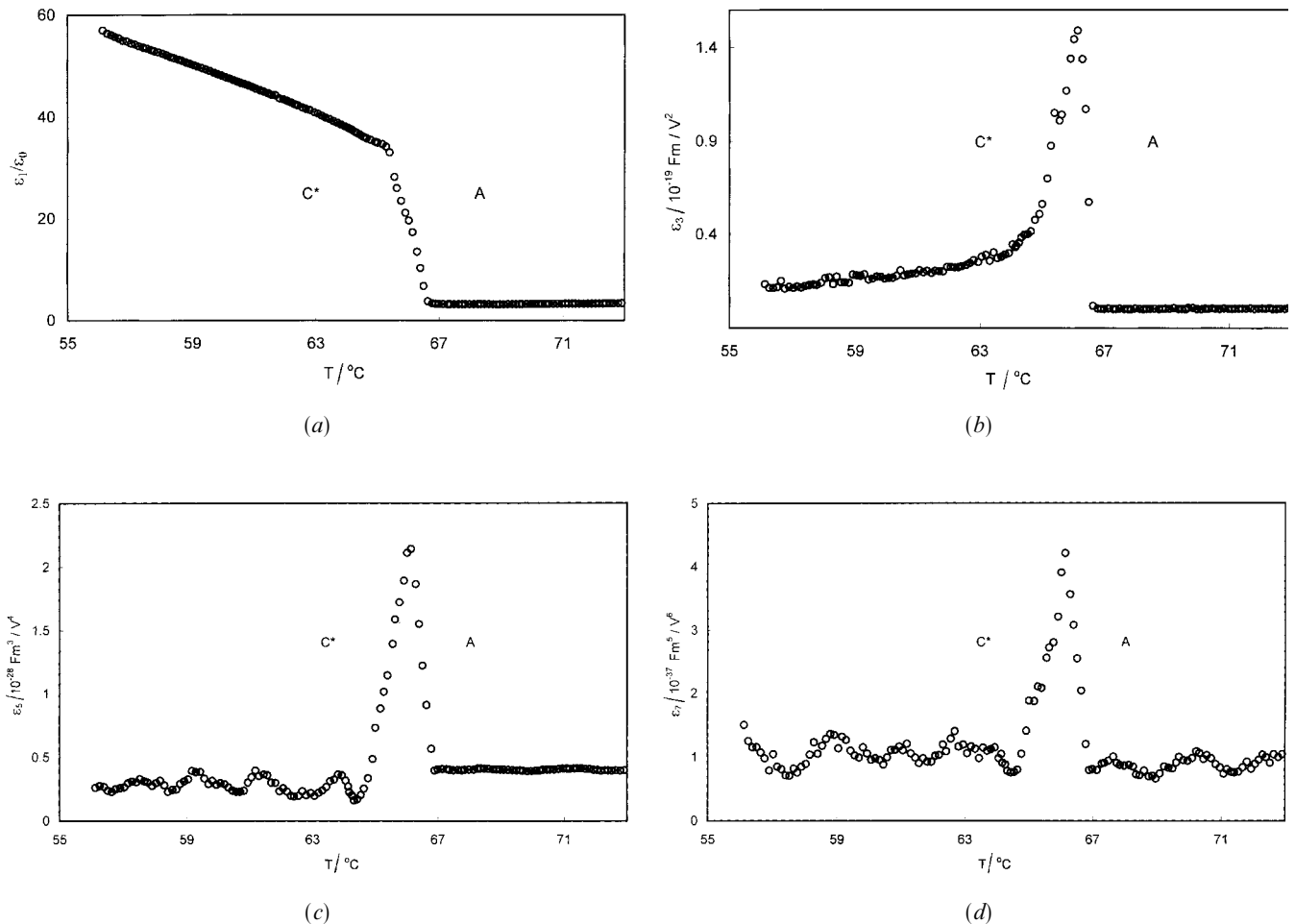

Figure 3. Temperature dependence of the (a) linear, (b) third order, (c) fifth order and (d) seventh order dielectric constants ϵ_1 , ϵ_3 , ϵ_5 and ϵ_7 .

Downloaded At: 19:00 25 January 2011

Thus, we feel that the magnitude of non-linearity can be directly related to the magnitude of the spontaneous polarization.

As mentioned earlier, the even harmonics were not observed owing to the presence of the helix in the sample cell. If the helix is unwound either by the application of a d.c. bias voltage or by surface forces in thin cells, it should be possible to measure the even harmonic responses. Experiments are in progress to perform such measurements.

In conclusion, we report a simple method of measuring non-linear dielectric responses. Using this method, we have been able to extract the responses of harmonics up to the seventh degree.

We thank Prof. S. Chandrasekhar for many useful discussions and E. Merck Ltd., Poole, UK for a free sample of SCE12.

References

- [1] See, for example, GOUDA, F., SKARP, K., and LAGERWALL, S. T., 1991, *Ferroelectrics*, **113**, 165.
- [2] ZIOLO, J., CHRAPEC, J., RZOSKA, S. J., and PYZUK, W., 1986, *Mol. Cryst. Liq. Cryst. Lett.*, **3**, 183.
- [3] CHELKOWSKI, A., 1980, *Dielectric Physics* (Amsterdam: Elsevier).
- [4] NAKADA, O., 1960, *J. phys. Soc. Jpn*, **15**, 2280.
- [5] FURUKAWA, T., NAKAJIMA, K., KOIZUMI, T., and DATE, M., 1987, *Jpn. J. appl. Phys.*, **26**, 1039.
- [6] KIMURA, Y., and HAYAKAWA, R., 1993, *Liq. Cryst.*, **14**, 427.
- [7] KIMURA, Y., and HAYAKAWA, R., 1993, *Jpn. J. appl. Phys.*, **32**, 4571.
- [8] NAIR, G. G., PRASAD, S. K., and CHANDRASEKHAR, S., 1995, *Mol. Cryst. Liq. Cryst.*, **263**, 311.
- [9] HUANG, C. C., DUMRONGRATTANA, S., NOUNESIS, G., STOFKO, J. J., and ARIMILLI, P. A., 1987, *Phys. Rev. A*, **35**, 1460.
- [10] Product Catalogue E. Merck Ltd.